

Розроблено математичну модель і досліджено втрату стійкості алюмінієвою бурильною трубою із зовнішнім протекторним потовщенням на середній ділянці під дією крутного моменту та осьової стискаючої сили. За результатами числового аналізу визначено величини критичних навантажень, при яких труба втрачає стійкість в залежності від форми протекторного потовщення. Запропоновано оптимальну обтічну форму протекторного потовщення. Розроблено нову конструкцію алюмінієвої бурильної труби з протекторним потовщенням

Ключові слова: бурильна труба, протекторне потовщення, крутний момент, осьова сила, стійкість, деформація

Разработана математическая модель и исследована потеря устойчивости алюминиевой бурильной трубы с внешним протекторным утолщением под воздействием крутящего момента и осевой сжимающей силы. На основе результатов численного анализа определены величины критических нагрузок, при которых происходит потеря устойчивости трубы в зависимости от формы протекторного утолщения. Предложена оптимальная обтекаемая форма протекторного утолщения. Разработана новая конструкция алюминиевой бурильной трубы с протекторным утолщением

Ключевые слова: бурильная труба, протекторное утолщение, крутящий момент, осевая сила, устойчивость, деформация

IMPROVING THE ALUMINUM DRILL PIPES STABILITY BY OPTIMIZING THE SHAPE OF PROTECTOR THICKENING

O. Vlasiiy

PhD, Associate Professor
Department of Informatics*
E-mail: olesia_vlasii@comp-sc.if.ua

V. Mazurenko

PhD, Associate Professor
Department of Differential Equations and Applied Mathematics*
E-mail: viktor.mazurenko@pu.if.ua

L. Ropyak

PhD, Associate Professor, Senior Researcher**
E-mail: l_ropjak@ukr.net

O. Rogal

Postgraduate Student**
E-mail: rogalex@ukr.net

*Vasyl Stafanyk Precarpathian National University
Shevchenko str., 57, Ivano-Frankivs'k, Ukraine, 76018
**Department of Computer Engineering Manufacturing
Ivano-Frankivsk National Technical
University of Oil and Gas
Karpatska str., 15, Ivano-Frankivsk, Ukraine, 76019

1. Introduction

In the process of drilling geological exploring and operating oil, gas and other wells, the drill pipes made of steel and light alloys are used. One of the key indicators of strength of drill pipes, which limits their use for deep drilling, is permissible stretching stresses in the point of hanging the drill string. The ratio between yield strength and specific weight of metals (at conditionally accepted $\sigma_r=400$ MPa) is: for steel – 5; titanium alloys – 9, aluminum alloys – 15; magnesium alloys – 22, which indicates the prospects of production of drill pipes from light metals. That is, the application of light alloys provides for a significant reduction in the level of stresses in drill pipes from their own weight and allows increasing the depth of well drilling.

Among the light alloys, in terms of distribution, physical-mechanical and technological properties and cost, aluminum alloys are beneficially distinguished. Compared with those made of steel, aluminum drill pipes (ADP) have certain other advantages. It is related to the manufacturing technology, corrosion resistance, damping and non-magnetic properties, cost of transportation and cost of drilling. The use of ADP in the construction of deep wells does not require increasing the capacity of a drilling device.

Well drilling is performed by the rotating method. In this case, chisel torque is transmitted from the surface-based rotor, or from a turbodrill or electric drill, embedded in the column of drill pipes, and axial load is created.

Drill pipes operate under difficult conditions: under the action of static and dynamic loadings at elevated temperatures, in the corrosion-active media of washing fluid that contains abrasive parts of the shattered rocks. The above-mentioned factors lead to the loss of stability of the drill pipe and corrosion-mechanical wear of its body in the course of contacts with the wall of the well. Therefore, when designing and developing technological processes for manufacturing and strengthening of drill pipes, special attention is paid to the issue of increasing their durability.

Thus, the development and optimization of designs of drill pipes and the technologies of their production are relevant and have important scientific and practical significance.

2. Literature review and problem statement

Since the drill string during operation is exposed to static and dynamic loads, predicting its behavior when working in the well is extremely difficult. That is why a large number

of papers are devoted to investigating the state of the drill string pipe.

In the process of drilling there occur significant vibrations, which negatively affect the drilling tools performance, downhole motors and ground equipment. Paper [1] considered the models that describe vibrations and allow the prediction of the axial, rotating and bending vibrations of drill string and proposed ways to reduce them. Article [2] examined dynamic bending of long drill columns of smooth tubes. That is, researchers focus on the studies of fluctuations of both a drill string pipe [1, 2] and the rod string [3].

Certain relevant issues related to analytical and numerical studies of the problems of statics, dynamics and stability of drill strings when drilling deep and sloping wells are covered in the recent publications. Thus, authors [4] examined the loss of stability of drill string of smooth tubes in the sloping well and demonstrated that the numerical results for the case when inclination angle of the well is equal to the angle of friction coincide with those obtained analytically. Researchers [5] studied the impact of rotation speed on the deflection of drill string and the magnitude of reaction in the zone of contact with the well wall. Paper [6] explored the loss of stability of drill string in vertical and horizontal wells and proposed a method for determining the permissible loads. Article [7] applied probabilistic approach when studying the behavior of drill string pipe under the action of operational loads with regard to the interaction with the rock of well wall. Paper [8] investigated stability of drill string when constructing deep wells that makes it possible to rationally choose the types of pipes and drilling locks, and demonstrated prospects of using pipes made of light alloys to reduce the cost of drilling.

Authors [9] studied the propagation of shock wave in an elastic rod with visco-elastic external resistance, simulating the elimination of drill string sticking. Researchers [10] examined the effect of mechanical properties of the pipes material on the dynamics of stuck drill string in the well.

That is, research [1, 2, 4–10] is mostly devoted to studying the behavior of drill string, mantled from smooth pipes, under loading.

For increasing the durability of aluminum drill pipes, the design, technological and operational methods are employed.

Design methods include the choice of method for joining parts of the drilling lock to the body of pipe, development of configuration of the conical threads, transient grooves and protectors' application. The latter can be formed directly on the body of pipe (protector thickening) or mantled on it (cover).

There is a standard drill pipe made of aluminum alloy, fabricated in line with the technical specifications of GOST 23786-79 (ISO 55226-85). It contains the main body of pipe with internal thickenings at the ends and protector thickening on the outer surface. Protector thickening is made in the form of a cylinder and two conical surfaces aligned with it. The shortcomings of standard ADP include low resistance to the application of axial force and the torque and high hydraulic resistance caused by the trapezoid-shaped protector thickening.

Among the technological methods, special attention should be paid to the rational shaping of billets, thermal treatment, optimization of the cutting modes and strengthening of conical lock threads, as well as the application of wear-resistant coatings on the surface of locks and body of ADP.

For improving the locks parts wear resistance, they traditionally apply welding of bands with the use of tungsten

carbide. However, this material is scarce and dissolves in the steel matrix. It is promising to use tungsten-free metal-carbide materials [11].

A method for strengthening drill pipes made of aluminum alloys was developed [12] by the local formation of oxide coating in electrolyte under the mode of spark and micro-arc discharges at the outer cylindrical surface. For the recovery of worn-out pipes it is advisable to use a dual-layer coating of the system "aluminum-aluminum oxide". The worn outer cylindrical surface of pipe made of aluminum alloy or steel is first coated with a layer of aluminum, and then its upper part is subjected to micro-arc oxidation for obtaining wear-resistant coating layer [13, 14].

Operational methods imply:

- special anti-corrosion treatment of drill pipes before inter-operational storage;
- rational arrangement of the pipe column, including periodic change in the location of pipes in the string to ensure their work under different temperature conditions and loads;
- reducing the level of vibrations;
- the choice of optimum drilling modes (frequency of rotation of the column of pipes, magnitude of axial load, torque, pressure and washing fluid consumption), as well as the selection of chemical formulation of washing fluid.

One of the promising ways to reduce vibrations is the application of drilling shock absorbers [15]. Authors of [16] developed an improved design of the indicator of fatigue damage, which is installed into the elements of interlocking connections of drill string pipe. The indicator status helps to predict the residual resource of work for a thread connection.

Aluminium drill pipes, due to high specific strength, resistance to corrosion and temperature drops, are gradually gaining leading positions in the practice of drilling deep and sloping wells. However, there is a lack of information on designing the ADP with protector thickening in the literature and this holds back their wide application. Thus it is necessary to optimize the design of drill pipe made of light alloy. For this purpose, protector thickening should be geometrically shaped, which would provide for maximum resistance of such a pipe under operational loads. In this case, it is important to ensure low hydraulic resistance to the motion of washing fluid in the well.

3. The aim and tasks of the study

The aim of present research is to improve such operational characteristics as stability and hydraulic resistance of aluminium drill pipe with protector thickening that is exposed to the action of torque and axial compressive force.

To achieve the set aim, the following tasks were to be solved:

- to devise a mathematical model of the compression and torsion of aluminium drill pipe of variable cross section under the condition of elastically fixed upper end and movable pinched bottom end of the pipe;
- to build approximation model for the original mathematical model and determine critical values of magnitudes of torque and axial force, exceeding of which causes the loss of stability of aluminium drill pipe with protector thickening of various shape;
- to optimize geometrical shape of protector thickening and develop a new design of aluminum drill pipe with improved performance characteristics.

4. Materials and methods of examining the impact of torque and axial force on the stability of aluminium drill pipe with the use of mathematical modeling

4. 1. Examined material

For the manufacture of aluminum drill pipe, aluminum deformed alloy of the brand D16T is used with chemical composition in line with GOST 4784-74. The pipes are produced in a hardened and naturally-aged condition. Their mechanical properties are: ultimate strength $\sigma_B=392-421$ MPa, conditional fluidity boundary $\sigma_{0.2}=255-274$ MPa, relative residual elongation $\delta=10-12$ %, longitudinal modulus of elasticity $E=72 \times 10^9$ Pa.

4. 2. Mathematical model and scheme of examining stability of aluminium drill pipe

4. 2. 1. Setting the problem

Aluminum drill pipe (ADP) (Fig. 1) will be considered as a cylindrical hollow (ring) rod of length L , whose upper end is elastically fixed in the drilling installation, while the lower end with a chisel is movably pinched. Let us consider that ADP is under the action of torque M and axial compressive force P . In this case, the forces of inertia caused by the rotation around vertical axis and the motion of washing fluid flow are disregarded.

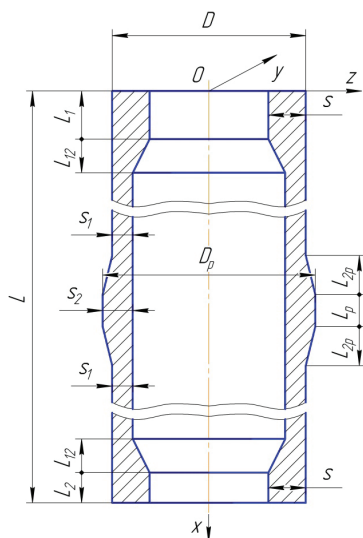

Fig. 1. Standard aluminum drill pipe with inner near-end and outer protector thickenings in the middle section (without coupling and nipple of the drilling lock)

As is accepted in the theory of stability of rods, we shall introduce the Oxyz coordinate system with the origin of coordinates in the point of hanging. The Ox axis is aligned with the axial line of ADP. As the principal axes of inertia of the cross section, we shall select the Oy and Oz axes. In such a coordinate system (Fig. 2) we shall explore the loss of ADP stability.

Let us consider ADP in a weakly deformed state, that is, at small elastic displacements of $y(x)$ and $z(x)$ along the xOy and xOz planes, respectively. That is why we disregard moments P_y and P_z . The torque, on the contrary, is essential, which is why we decompose it into components M_y' and M_z' by the axial directions (Fig. 2, b). For this case, the system of differential equations of elastic deformation of ADP takes the form [17]:

$$\begin{cases} -EI(x)z'' = Pz - My', \\ -EI(x)y'' = Py + Mz', \end{cases} \quad (1)$$

where E is the modulus of elasticity (Young), $I(x)$ is the moment of inertia of cross-section of the pipe with abscissa in the point x . The system of differential equations (1) will be examined together with boundary conditions

$$y(0) - z(0) = z'(0) = 0, \quad y'(L) = z'(L) = 0, \quad (2)$$

that satisfy the above-specified type of fixing the ADP ends.

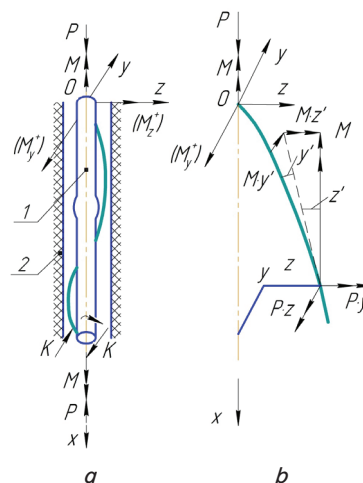

Fig. 2. Aluminum drill pipe with the applied loads: a - design scheme; b - strained state under the action of compression and torsion; 1 - aluminum drill pipe with protector thickening; 2 - wall of well

ADP has a variable cross section (Fig. 1, 2, a). Let us split it into sections, within which the cross section changes by the defined rule:

- $[x_0; x_1)$ and $[x_4; x_5)$ - sections of upper and bottom inner near-end thickenings, respectively;
- $[x_1; x_2)$ and $[x_3; x_4)$ - sections of transition from the upper and bottom near-end thickenings relative to the main cross section of the ADP body;
- $[x_2; x_3)$ - section of the outer protector thickening

Then the ADP bending rigidity is described by one analytical expression in the form of

$$EI(x) = \sum_{k=0}^4 EI_k(x) \Theta_k(x),$$

where $I_k(x)$ is the moment of inertia of the cross section of ADP in section

$$x \in [x_k; x_{k+1}), \quad \Theta_k(x) = \begin{cases} 1, & x \in [x_k; x_{k+1}), \\ 0, & x \notin [x_k; x_{k+1}) \end{cases}$$

is the characteristic function of this section. Since the ADP cross section takes the form of a ring, then:

$$I_k(x) = \frac{E\pi D_k^4(x)}{64} \left[1 - \left(\frac{d_k(x)}{D_k(x)} \right)^4 \right], \quad k = \overline{0, 4},$$

where $d_k(x)$, $D_k(x)$ are, respectively, the inner and outer diameters of ADP in the section $x \in [x_k; x_{k+1})$, which are determined by the ADP diameter, thicknesses of walls of the

main cross section and near-end thickenings, thickness of wall and the shape of protector thickening.

4. 2. 2. Reduction to the first order differential system

By introducing two-dimensional vector

$$V(x) = (z(x), y(x))^T$$

and square matrices of second order

$$A(x) = (EI(x))^{-1} J, \quad B(x) = (EI(x))^{-1} E_2,$$

where

$$(EI(x))^{-1} = \sum_{k=0}^4 (EI_k(x))^{-1} \Theta_k(x),$$

$$J = \begin{pmatrix} 0 & -1 \\ 1 & 0 \end{pmatrix}, \quad E_2 = \begin{pmatrix} 1 & 0 \\ 0 & 1 \end{pmatrix}$$

we shall reduce boundary problem (1), (2) to the form

$$V'' + MA(x)V' + PB(x)V = 0, \tag{3}$$

$$V(0) = 0, \quad V'(l) = 0. \tag{4}$$

Next, using four-dimensional vector

$$U(x) = (V(x), V'(x))^T$$

and square matrix of fourth order $C(x)$, which has a block structure

$$C(x) = \begin{pmatrix} O_2 & E_2 \\ -PB(x) & -MA(x) \end{pmatrix},$$

where O_2 is zero matrix of second order, boundary problem (3), (4) will be rewritten in the form of boundary problem for the first order differential system

$$U' = C(x)U, \tag{5}$$

$$RU(0) + SU(l) = 0 \tag{6}$$

with boundary matrices

$$R = \begin{pmatrix} E_2 & O_2 \\ O_2 & O_2 \end{pmatrix} \text{ and } S = \begin{pmatrix} O_2 & O_2 \\ O_2 & E_2 \end{pmatrix}.$$

We shall obtain a general solution of boundary problem (5), (6):

$$U(x) = K(x, P, M)C, \tag{7}$$

where $K(x, P, M)$ is the fundamental Cauchy matrix of system (6), normalized by condition $K(0, P, M) = E_2$, and C is the arbitrary sustainable four-dimensional vector. To receive C , let us substitute general solution (7) into boundary conditions (6). We shall obtain a system of linear algebraic equations

$$[R + SK(l, P, M)]C = 0. \tag{8}$$

The P and M parameters values are critical if the characteristic determinant of this system is

$$\Delta(P, M) \equiv \det[R + SK(l, P, M)] = 0.$$

These parameters are met by non-trivial solutions of system (8), and, therefore, boundary problem (5), (6), which determine forms of the ADP stability loss.

The main problem in the application of this scheme is building a fundamental matrix. Since system (5) is the system of differential equations with piecewise-smooth coefficients, then it is impossible to find a Cauchy matrix in analytical form. That is why we have to apply different approximate procedures. We shall apply a method for solving an approximating problem proposed in paper [18].

4. 2. 3. Building an approximating model

Let us split the main section $[0, l]$ into n equal parts of length

$$h = \frac{l}{n}: \quad 0 \equiv \xi_0 < \xi_1 < \dots < \xi_k < \xi_{k+1} < \dots < \xi_n \equiv l.$$

At each interval $[\xi_k, \xi_{k+1})$ we approximate block matrix $C(x)$ as follows. We shall apply D-approximation (discretization [19]) to the primary $b(x)$ matrix-function $B(x)$ and L-approximation (linearization) – to the primary $a(x)$ matrix-function $A(x)$. In other words, we shall approximate the mentioned primaries element by element at each interval $[\xi_k, \xi_{k+1})$ by step and linear functions, respectively. We shall obtain:

$$b(x) \approx b(\xi_k), \quad x \in [\xi_k, \xi_{k+1})$$

and

$$a(x) \approx \frac{a(\xi_{k+1}) - a(\xi_k)}{h} x, \quad x \in [\xi_k, \xi_{k+1}).$$

After differentiation, we receive approximations

$$B(x) \approx \sum_{k=1}^n c_k \delta(x - \xi_k) E_2 \text{ and } A(x) \approx \sum_{k=1}^n \frac{c_k}{h} \Theta(x) J$$

for $x \in [0, l]$, and corresponding approximated system of first order differential equations with pulsed coefficients:

$$\begin{pmatrix} V_n \\ V_n' \end{pmatrix}' = \begin{pmatrix} O_2 & E_2 \\ -P \left[\sum_{k=1}^n c_k \delta(x - \xi_k) \right] E_2 & -M \left[\sum_{k=1}^n \frac{c_k}{h} \Theta_k(x) \right] J \end{pmatrix} \begin{pmatrix} V_n \\ V_n' \end{pmatrix}, \tag{9}$$

where

$$c_k = \int_{\xi_k}^{\xi_{k+1}} (EI(x))^{-1} dx,$$

$\delta(x - \xi_k)$ is the Dirac function with carrier in point ξ_k , $\Theta_k(x)$ is the characteristic function of interval $[\xi_k, \xi_{k+1})$. Matrix of coefficients jumps of system (9) takes the form

$$VC_n(x) = \begin{pmatrix} O_2 & O_2 \\ -Pc_k E_2 & O_2 \end{pmatrix}.$$

For all $x \in [0, l]$ satisfies the so-called correctness condition $[VC_n(x)]^2 = O_4$. This condition warrants that when examining system (9) there will not appear the problem of multiplication of generalized functions (Schwartz distributions). We shall note that the matrix-function cannot be

approached with D-approximation, because, in this case, the approximated system that could have been obtained would prove incorrect in generalized sense.

Boundary conditions for system (9) take the form similar to (6):

$$R(V_n, V_n')^T(0) + S(V_n, V_n')^T(l) = 0. \tag{10}$$

It is known from [22] that the solution of boundary problem (9), (10) coincides at $n \rightarrow \infty$ evenly in the segment [0,1] to the solution of boundary problem (5), (6).

Let us note that the transition from system (5) with regular coefficients to system (9) with singular coefficients appears to be not rational at first glance. However, it has a significant advantage over other alternative approaches to solving boundary problem (5), (6) in that it is possible to build exact solution to approximating problem (9), (10) whose values in points $\xi_k, k=1, n$ can be calculated by recurrent formulas:

$$\begin{pmatrix} V_n(\xi_k) \\ V_n'(\xi_k) \end{pmatrix} = \begin{pmatrix} E_2 & O_2 \\ -Pc_k E_2 & E_2 \end{pmatrix} \times \begin{pmatrix} E_2 & -\frac{h}{Mc_k} J[E_2 - e^{-Mc_k J}] \\ O_2 & e^{-Mc_k J} \end{pmatrix} \cdot \begin{pmatrix} V_n(\xi_{k-1}) \\ V_n'(\xi_{k-1}) \end{pmatrix}, \tag{11}$$

where

$$e^{-Mc_k J} = \begin{pmatrix} \cos(Mc_k) & \sin(Mc_k) \\ -\sin(Mc_k) & \cos(Mc_k) \end{pmatrix}.$$

After substituting (11) into boundary condition (10), we shall obtain a system of linear algebraic equations, whose characteristic determinant takes the form

$$\Delta_n(P, M) = \det \left[R + S \prod_{k=0}^{n-1} \begin{pmatrix} E_2 & -\frac{h}{Mc_{n-k}} J[E - e^{-Mc_{n-k} J}] \\ -Pc_{n-k} E_2 & -\frac{Ph}{M} J[E - e^{-Mc_{n-k} J}] + e^{-Mc_{n-k} J} \end{pmatrix} \right]. \tag{12}$$

Zeros of determinant (12) are critical values of the P and M parameters. Thus, by successively setting the values of torque M, we can calculate the relevant critical values of axial force P and vice versa.

5. Results of examination of stability of aluminium drill pipe with protector thickening of various shapes

By the above-obtained formulas, we performed numerical calculations for examining the influence of geometrical shape of outer protector thickening on the stability of aluminum drill pipe, whose design scheme is depicted in Fig. 1, 2, with the following input data: $L=12$ m, $L_1=1.3$ m, $L_2=L_{12}=0.25$ m, $L_p=0.3$ m, $L_{2p}=1.5$ m, $D=0.129$ m, $D_p=0.15$ m, $s=0.017$ m, $s_1=0.011$ m, $s_2=0.0215$ m, $E=72 \times 10^9$ Pa – modulus of elasticity of aluminum deformed alloy of the brand D16T.

We considered certain characteristic geometric shapes of protector thickening, which are described by analytical expressions for functions (Table 1, Fig. 3) from such classes as linear splines (triangular and trapezoidal shapes), quadratic

functions, fractional-rational functions, exponential functions. Let us note that $d(x)$ is the diameter of cross-section of ADP with abscissa at point x in the section of protector thickening. All constants in the analytical expressions are calculated explicitly by the input data (explicit formulas for the constants are not listed here only to avoid the cumbersome entries in Table 1).

ADP under the action of torque $M=80000$ Nm was considered. Critical values of axial force P_{cr} for various geometric shapes of protector thickening are shown in the third column of Table 1.

We also considered ADP under the action of axial compressive force $P=30000$ N. The critical values of torque M_{cr} obtained for various geometric shapes of protector thickening are shown in the fourth column of Table 1.

Table 1

Results of calculation of critical values of axial force and torque, at which the stability of aluminum drill pipe with different shape of protector thickening is lost

Number	Shape of protector thickening	P_{cr} N	M_{cr} Nm
1	$\frac{d}{2} = 0.0645, 0 \leq x \leq 12$	35077	129950
2	$\frac{d}{2} = \begin{cases} 0.0064x + 0.0367, & 4.35 \leq x \leq 6 \\ -0.0064x + 0.1135, & 6 \leq x \leq 7.65 \end{cases}$	36033	148330
3	$\frac{d}{2} = \begin{cases} 0.0070x + 0.0341, & 4.35 \leq x \leq 5.85 \\ 0.0750, & 5.85 \leq x \leq 6.15 \\ -0.0070x + 0.1181, & 6.15 \leq x \leq 7.65 \end{cases}$	36087	149530
4	$\frac{d}{2} = -0.0039(x-6)^2 + 0.075, 4.35 \leq x \leq 7.65$	36301	153580
5	$\frac{d}{2} = \frac{0.0105}{0.7779 + (x-6)^2} + 0.0615, 4.35 \leq x \leq 7.65$	35896	145980
6	$\frac{d}{2} = \frac{0.0081}{0.6705 + x-6 ^3} + 0.0629, 4.35 \leq x \leq 7.65$	35949	147200
7	$\frac{d}{2} = \frac{0.0106}{0.9005 + (x-6)^4} + 0.0632, 4.35 \leq x \leq 7.65$	36041	149120
8	$\frac{d}{2} = 0.0136 \exp\left(-\frac{(x-6)^2}{1.8444}\right) + 0.0614, 4.35 \leq x \leq 7.65$	36102	149950
9	$\frac{d}{2} = 0.0110 \exp\left(-\frac{ x-6 ^3}{1.4690}\right) + 0.0640, 4.35 \leq x \leq 7.65$	36104	150080
10	$\frac{d}{2} = 0.0109 \exp\left(-\frac{(x-6)^4}{2.2925}\right) + 0.0641, 4.35 \leq x \leq 7.65$	36209	152270

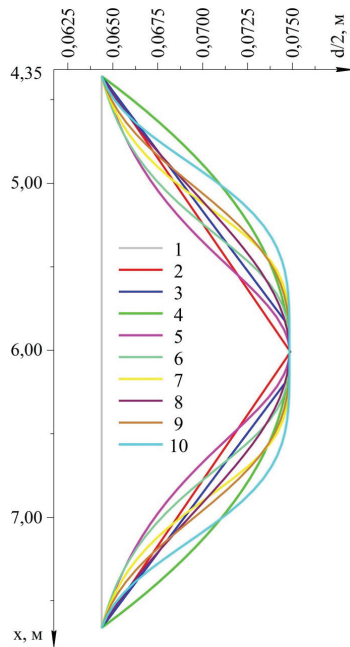

Fig. 3. Variants of geometric shape of protector thickening of aluminum drill pipe (the numbering of lines is in accordance with Table 1)

We can see from Table 1 that maximum critical loads correspond to the parabolic shape of protector thickening, but such a form of protector thickening (Fig. 3) does not provide for a low hydraulic resistance to the motion of washing fluid. The danger of turbulence of the flow of washing fluid in the zone of transition from protector thickening to the main body of ADP is real and it is the concentrator of mechanical stresses in the transition zone. Therefore, optimal is the last exponential shape from Table 1 (number 10), which belongs to the class of streamline forms and is described by a function of the form

$$d_\epsilon(x) = \alpha e^{-\epsilon \left(x - \frac{l}{2}\right)^4} + \beta, \tag{13}$$

where ϵ is the parameter that is responsible for the streamlined shape of protector thickening, in this case, $0.3 \leq \epsilon \leq 0.7$ (for shape 10 from Table 1 $\epsilon \approx 0.4$); α and β are the coefficients of function, which are determined by the input data:

$$\alpha = \frac{D_p - D}{1 - e^{-\frac{\epsilon l_{pr}^4}{16}}}, \quad \beta = \frac{D - D_p e^{-\frac{\epsilon l_{pr}^4}{16}}}{1 - e^{-\frac{\epsilon l_{pr}^4}{16}}},$$

where l_{pr} is the length of protector thickening, $l_{pr} = L_p + 2L_{2p}$.

According to results of the research, we devised a new design of aluminum drill pipe with a protector thickening (Fig. 4) and the technology of its manufacture. Protector thickening becomes an additional support, due to which tension in a bended pipe reduces and its wear slows down in the place of contact with the wall of the well during drilling.

In the process of drilling, a column of ADP pipes is formed (Fig. 4) that revolves and gradually descends into the borehole. To deepen the borehole, the column is gradually building up. After this, washing fluid is fed into the inner cavity of the column pipe, and the required axial effort and torque are applied that provide the rotation of this column of drill pipes. Energy is transmitted to the drilling chisel, which destroys

the rock breed at the bore downhole. The washing fluid that contains particles of the shattered rock ascends to the surface through a ring gap between the outer surface of the drill pipe and the borehole wall. The presence of protector thickening of the proposed streamlined shape provides high ADP stability, collected in the column, low hydraulic resistance to the motion of washing fluid. The wear resistance of the outer surface of the pipe in the place of protector thickening also increases during its friction with the wall of steel casing column or well-bore wall both in the process of drilling and when conducting descending-lifting operations. The microarc oxide coating is being formed on protector thickening of ADP for exploitation at abrasive environment.

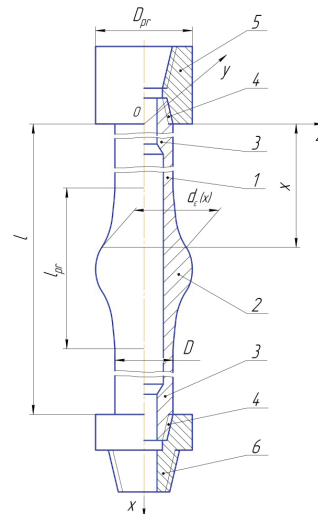

Fig. 4. General view of the developed design of aluminum drill pipe with a protector thickening of optimal shape:
 1 – body of the pipe; 2 – protector thickening;
 3 – inner near-end thickening; 4 – threaded connection;
 5 – coupling of the drilling lock; 6 – nipple of the drilling lock

6. Discussion of results of examining the influence of shape of protector thickening on the stability of aluminium drill pipe

The studies conducted have demonstrated that the use of aluminum drill pipes with a protector thickening of streamlined shape provides improved stability of the drill string. The research results make it possible to argue that the developed design of aluminum drill pipe has improved performance characteristics: higher stability and lower hydraulic resistance. In future such an ADP may be recommended for the implementation at drilling enterprises when constructing deep wells, which will reduce the cost of drilling and increase the volumes of oil and gas extraction.

Thus, the results of research obtained have proved the possibility of directed control over stability of aluminum drill pipes through the scientifically-substantiated selection of optimal streamlined shape of protector thickening in the middle section of the pipe, which is described by an exponential function. That is why the obtained results of mathematical modeling might be regarded as the evidence base regarding the prospects of practical application of the optimal shape of protector thickening in the production of aluminum drill pipes at specialized enterprises such as TzOV “Interbur” (Ivano-Frankivsk, Ukraine).

Much to our regret, the developed mathematical model did not account for the eccentricity of protector thickening relative to the axis of aluminum drill pipe when determining its stability under load. That is why further research is planned to take into account the effect of eccentricity of protector thickening relative to the axis of aluminum drill pipe on its stability under load and the resource of work.

7. Conclusions

A mathematical model of elastic deformation of aluminum drill pipe under the action of compression and torsion forces is developed, which takes into account a change in the moment of inertia of its cross section along the Ox axis and conditions of elastic fixing of the upper end and movable pinching of the bottom end of the pipe.

We built approximating model by the method of linearization and discretization for the original mathematical

model and calculated, depending on the geometrical shape of protector thickening, critical values of the magnitudes of torque and axial force, exceeding of which leads to the loss of stability of aluminium drill pipe. It is demonstrated that protector thickening of trapezoidal shape provides increased magnitude of critical axial force by 1.029 times and of critical torque by 1.151 times, of exponential shape – by 1.032 times and 1.172 times, compared with a smooth pipe (without protector thickening), respectively. It is established that the shape of protector thickening does not exert significant influence on the magnitude of critical axial force, but to a larger extent affects the magnitude of critical torque.

It was found that the optimal geometric shape of protector thickening is a streamlined shape, which is described by exponential function and provides, compared to other characteristic shapes, better performance characteristics: higher stability and lower hydraulic resistance, which allowed us to develop a new design of aluminium drill pipe.

References

1. Ghasemloonia, A. A review of drillstring vibration modeling and suppression methods [Text] / A. Ghasemloonia, D. Geoff Rideout, S. D. Butt // *Journal of Petroleum Science and Engineering*. – 2015. – Vol. 131. – P. 150–164. doi: 10.1016/j.petrol.2015.04.030
2. Gulyayev, V. I. Free vibrations of drill strings in hyper deep vertical borewells [Text] / V. I. Gulyayev, O. I. Borshch // *Journal of Petroleum Science and Engineering*. – 2011. – Vol. 78, Issue 3-4. – P. 759–764. doi: 10.1016/j.petrol.2011.09.001
3. Steliga, I. An experimental and theoretical method of calculating the damping ratio of the sucker rod column oscillation [Text] / I. Steliga, Ja. Grydzhuk, A. Dzhus // *Eastern-European Journal of Enterprise Technologies*. – 2016 – № 2 (7 (80)). – P. 20–25. doi: 10.15587/1729-4061.2016.66193
4. Musa, N. Critical buckling of drill strings in cylindrical cavities of inclined bore-holes [Text] / N. Musa, V. Gulyayev, N. Shlyun, H. Aldabas // *Journal of Mechanics Engineering and Automation*. – 2016. – Vol. 6, Issue 1. – P. 25–38. doi: 10.17265/2159-5275/2016.01.004
5. Major, I. E. Effect of drill string rotation on the dynamic response of drilling risers [Text] / I. E. Major, A. Big-Alabo, S. Odi-Owei // *International Journal of Applied Mechanics and Engineering*. – 2015. – Vol. 20, Issue 3. – P. 503–516. doi: 10.1515/ijame-2015-0034
6. Sun, Y. A simple and accurate numeric solution procedure for nonlinear buckling model of drill string with frictional effect [Text] / Y. Sun, Y. Yu, B. Liu // *Journal of Petroleum Science and Engineering*. – 2015. – Vol. 128. – P. 44–52. doi: 10.1016/j.petrol.2015.02.026
7. Ritto, T. G. Nonlinear dynamics of a drill-string with uncertain model of the bit-rock interaction [Text] / T. G. Ritto, C. Soize, R. Sampaio // *International Journal of Non-Linear Mechanics*. – 2009. – Vol. 44, Issue 8. – P. 865–876. doi: 10.1016/j.ijnonlinmec.2009.06.003
8. Masoomi, R. Mathematical modeling and prediction of drill string stability region [Text] / R. Masoomi, J. Moghadasi // *Journal of Petroleum Exploration and Production Technology*. – 2014. – Vol. 4, Issue 4. – P. 351–358. doi: 10.1007/s13202-013-0097-3
9. Shatskii, I. P. Shock-wave propagation in an elastic rod with a viscoplastic external resistance [Text] / I. P. Shatskii, V. V. Perepichka // *Journal of Applied Mechanics and Technical Physics*. – 2013. – Vol. 54, Issue 6. – P. 1016–1020. doi: 10.1134/s0021894413060163
10. Levchuk, K. G. Vplyv mehanichnyh vlastyvoستي materialu na dynamiku pryhoplenyh burylnykh trub [Text] / K. G. Levchuk, V. M. Moisyshyn, I. V. Cidylo // *Physics of Metals*. – 2016. – Vol. 38, Issue 12. – P. 1594–1607.
11. Kryl, Ya. A. Structure formation and properties of NbC-Hadfield steel cermets [Text] / Ya. A. Kryl, P. M. Prysyazhnyuk // *Journal of Superhard Materials*. – 2013. – Vol. 35, Issue 5. – P. 292–297. doi: 10.3103/s1063457613050043
12. The Patent of Ukrainta, Sposib zmitsnennya burylnykh trub iz alyuminiyevykh splaviv [Text] / Ropyak L. Ya., Rogal O. V. – Ivano-Frankivsk National Technical University of Oil and Gas. a201114404; declared: 05.12.11; published: 25.10.13, Bul. 20, 4.
13. Student, M. M. Tribological properties of combined metal-oxide–ceramic layers on light alloys [Text] / M. M. Student, V. M. Dovhunyk, M. D. Klapkiv, V. M. Posuvailo, V. V. Shmyrko, A. P. Kytsya // *Materials Science*. – 2012. – Vol. 48, Issue 2. – P. 180–190. doi: 10.1007/s11003-012-9489-7
14. Shatskyi, I. P. Strength optimization of a two-layer coating for the particular local loading conditions [Text] / I. P. Shatskyi, L. Ya. Ropyak, M. V. Makoviichuk // *Strength of Materials*. – 2016. – Vol. 48, Issue 5. – P. 726–730. doi: 10.1007/s11223-016-9817-5
15. Velichkovich, A. S. Assessment of stressed state and performance characteristics of jacketed spring with a cut for drill shock absorber [Text] / A. S. Velichkovich, T. M. Dalyak // *Chemical and Petroleum Engineering*. – 2015. – Vol. 51, Issue 3. – P. 188–193.
16. Shats'kyi, I. P. Combined Deformation Conditions for Fatigue Damage Indicator and Well-Drilling Tool Joint [Text] / I. P. Shats'kyi, O. M. Lyskanych, V. A. Kornuta // *Strength of Materials*. – 2016. – Vol. 48, Issue 3. – P. 469–472. doi: 10.1007/s11223-016-9786-8
17. Collatz, L. Eigenwertaufgaben mit technischen anwendungen [Text] / L. Collatz. – Leipzig: Akademische Verlagsgesellschaft Geest & Portig K.-G., 1963. – 490 p.
18. Tatsii, R. M. Uzahalneni kvazidyferentsialni rivniannia [Text] / R. M. Tatsii, M. F. Stasiuk, V. V. Mazurenko, O. O. Vlasii. – Drohobych: Kolo, 2011. – 301 p.
19. Tatsii, R. M. Rozviazannia zadach pro vtratu stiikosti stryzhniv z dyskretno-neperervnym rozpodilom parametriv metodom dyskretyzatsii [Text] / R. M. Tatsii, T. I. Ushak // *Mashynoznavstvo*. – 2009. – Vol. 5, Issue 143. – P. 41–47.